

SOFF-CUT
INTERNATIONAL, INC.

Model X-450 Operating Guide



IMPORTANT:
Read ALL Directions Before Using

CONTENTS

Safety warnings	3
Symbols	4
Machine description and specifications	5
Sound data	6
Vibration data	6
Unpacking	6
Transporting	6
Blade and skid plate installation	7
Operating instructions	8
Maintenance	10
Sawing joints	11
Trouble shooting	12
Warranty	13
Maximizing the Soff-Cut system	14

Manufacturer	Soff-Cut International 1112 Olympic Drive Corona, CA 92881 USA
Model	X-450
Serial number	_____
Year manufactured	_____

WARNING: Failure to comply with the following warnings could result in serious bodily injury or death!

SAFETY WARNINGS

PERSONAL SAFETY

- Read and understand instructions before operating saw.
- Always wear safety approved hearing, eye, head and respiratory protection.
- Wear boots with non-slip soles to provide proper footing. Steel-toed safety boots are recommended.
- Wear rubber work gloves to avoid contact with wet concrete which can cause serious skin irritation.
- Know how to stop the saw quickly in case of emergency.
- Keep all parts of your body away from blade and other moving parts. Do not wear loose clothing or jewelry which can be caught in moving parts. Wear protective hair covering to contain long hair.
- Use caution when loading and unloading saw.
- Stay alert. Maintain awareness of saw operation. Use common sense. Do not operate saw when tired or after consumption of any substance that would impair physical function or rational judgement.
- Do not over reach. Keep proper footing and balance.

WORK AREA SAFETY

- Never operate the saw in any application or job where you are not trained or supervised.
- Keep visitors, children and animals out of the work area.
- Observe all safety regulations for the safe handling of fuel. Gasoline is extremely flammable and its vapors can explode if ignited. Do not refuel indoors or in poorly ventilated areas. Handle fuel in safety containers. Shut off the engine and allow it to cool before refueling. Wipe the saw dry if fuel is spilled on it. Always move away from the fueling area before starting the engine. Do not smoke while refueling.
- Do not operate the saw while smoking or near an open flame.
- Do not operate the saw in areas of combustible material or fumes. Sparks may occur from the saw that could cause a fire or explosion.
- Operate only in well ventilated areas. Engine exhaust contains carbon monoxide which can cause loss of consciousness and possible death.
- The muffler and engine become very hot during operation. Keep all body parts and foreign material away from the engine while running.
- Avoid dangerous environments. Do not use the saw in damp or wet locations. Do not expose saw to rain. Keep work area well lit and clean.























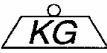

SAW SAFETY

- Do not leave saw unattended while the engine is running.
- Do not alter the saw. Any alteration or modification is misuse and may result in a dangerous condition.
- All safety guards must be in place before starting engine.
- Only operate the saw from behind the machine with both hands on the handle.
- Do not use damaged equipment, blades, guards or personal protection equipment. Do not disable safety equipment or kill switches.
- Do not operate the saw if there is a fuel leak.
- Use extreme caution when maneuvering the saw on ramps or loading and unloading from trucks or trailers.
- Use only Soff-Cut International, Inc. replacement parts. Use of unauthorized parts may create a danger.
- Do not use the saw as a vehicle for transporting personnel or equipment.
- Remove the ignition cable from the spark plug before performing saw maintenance or changing blades to prevent accidental engine starting.
- Remove all wrenches from the saw before starting.
- Never stand on the saw.
- When the saw is not in use or transporting, remove the blade and lower the saw completely. Properly secure the saw to prevent accidental movement.

BLADE SAFETY

- Examine cutting blades before each use. Do not use any blade that has cracks, nicks, or flaws. Tri-arbor hole should be undamaged. Use only dry cut, steel centered, tri-arbor diamond blades made for cutting green concrete.
- Soff-Cut International, Inc. diamond blades are designed to only cut green concrete. Cutting any other material may result in blade failure or a dangerous condition.
- Inspect blade flanges for damage, excessive wear and cleanliness before mounting the blade. The blade should fit snugly on clean, undamaged, tri-arbor shaft.
- Use only Soff-Cut blades or blades marked with a maximum operating speed greater than 3200 rpm.
- Never operate the saw without the blade block assembly securely in place including blade cover, lexan shields and skid plate installed in working order. A damaged blade block assembly must be replaced to protect the operator.
- Make sure the blade does not make contact with the ground or any other surface when maneuvering the saw.
- Avoid getting in direct line with the blade or contacting the blade while it is rotating

SYMBOLS

	Read manuals before operating.		Use in well ventilated area.
	Machine conforms with applicable European directive.		Do not use in flammable areas.
	Wear approved hearing protection		Machinery hazard – keep hands and feet clear.
	Wear approved eye protection		Keep all guards in place.
	Wear approved respiratory protection.		Machinery hazard – stay clear of moving components.
	Wear approved head protection.		Lifting point
	Diamond blade		Remove the blade prior to hoisting, loading, unloading and transporting the machine.
	Rotational speed in revolutions per minute (rpm)		Engine
	Machine mass		Engine speed in revolutions per minute (rpm)
	Lower blade in to the concrete		Electrical switch – Off
	Raise blade out of the concrete		Electrical switch – On
	Lower front guide		Raise front guide

MACHINE DESCRIPTION

The Soff-Cut International, Inc. **Model X-450** is designed as a residential and light commercial Ultra Early Entry concrete saw. The patented Soff-Cut Ultra Early Entry dry cutting system controls random cracking of concrete through the early timing of the saw cutting usually within one to two hours after the finishing process is completed. The patented low noise and low dust blade block and skid plate technology in conjunction with Soff-Cut blades allows for Ultra Early Entry sawing the same day while minimizing chipping and spalling. The saw is a manual push style with manual controls for all functions.

Model number – X-450

Materials cut – Green concrete only.

Blade type – 10” (254mm) dry cut with tri-arbor

Blade rotation – Counter clockwise, upcutting

Blade shaft speed – 3350 rpm

Cutting depth – 1” to 1 3/16” (25 to 30mm) depending on amount of blade wear

Cutting distance from wall – 3” (76mm)

Dry weight – 132 lbs (60 kg)

Operating weight – 139 lbs (63 kg) fuel and oil full

Dimensions –34”L x 19”W x 21”H (864mmL x 483mmW x 533mmH)

Fuel – Unleaded gasoline only with 87 or higher octane rating

Oil – SAE 10W-30 viscosity detergent automotive type with API service class SE or higher grade

Blade raise/lower system – Manual with remote release on handlebar

Guide system – Manual front guide with remote lever on handlebar with triangle blade block guide and rear pointer on wheel

Handle – Folding type with locking knob

Lifting point – Handle folded down and in locked position

Average cutting rate - Estimate only. Speed will vary with job conditions and concrete mixes.

Soft aggregates	13 ft/min (4 m/min)
Medium aggregates	9 ft/min (2.7 m/min)
Hard aggregates	5 ft/min (1.5 m/min)

Blade applications

Purple Excel Series 1000	XL8-1000	Ultra hard aggregate and non abrasive sand
Green Excel Series 2000	XL8-2000	Hard to ultra hard aggregate and non abrasive sand
Red Excel Series 3000	XL8-3000	Hard aggregate, medium abrasive sand
Orange Excel Series 4000	XL8-4000	Medium hard aggregate, medium abrasive sand
Yellow Excel Series 5000	XL8-5000	Medium hard to soft aggregate, abrasive sand
Black Excel Series 6000	XL8-6000	Soft aggregate, highly abrasive sand

Blades are available in 8” (203mm) diameter and in .100” and .250” (2.5mm and 6.4mm) widths.

Engine specifications

Type	Air cooled, 4-cycle, single slant cylinder, overhead camshaft, gasoline engine
Model	Robin EX17
Power	5.7 hp (4.2 kW)
Oil capacity	.6 quart (.6 liter)
Fuel capacity	.95 gallon (3.6 liter)
Starting system	Manual recoil starter
Air filter	Cyclonic type
Oil system	Oil alert with auto shut down sensor
Muffler	Silent type 77 dbA, exhaust deflector, spark arrestor
Emissions	Complies with EPA Phase 2 and CARB Tier II USA regulations
Cooling	Air cooled with external cooling fins
Cylinder	Aluminum with cast iron liner
Controls	Engine mounted fuel shut off lever. Remote mounted manual engine on/off switch, engine throttle lever, engine choke lever, guide lever, blade lower lever, engine tachometer and hour meter.

!WARNING!

The engine exhaust from this product contains chemicals known to the State of California, USA, to cause cancer, birth defects or other reproductive harm.

SOUND DATA

According to Standard *ISO 3744:1998* and *Directive 2000/14/EC* for environmental sound level and according to *Standard ISO 11201:1995* for sound level at the operator's position, the Soff-Cut **Model X-450** saw emits the following:

Sound power level	Lwa 102 dB (A)
Sound pressure level	Lpa 86 dB (A)

WARNING: Always wear safety approved hearing protection.

VIBRATION DATA

According to Standard *ISO 5349-2:2001* for hand-arm transmitted vibrations in the handles the Soff-Cut **Model X-450** saw emits the highest vibrations at the left hand handle of 31.8 ft/sec^2 (9.7 m/s^2) average.

UNPACKING

Your Soff-Cut **Model X-450** saw has been shipped from the factory thoroughly inspected. No assembly is required to start using the saw. Remove the saw from the container using proper lifting techniques. Discard or recycle the packing material per your regional laws. In your container will be the X-450 saw, a blade shaft wrench, an owner's manual, an engine owner's manual, a parts list, a warranty card, a joint protector pack, a diamond blade, a skid plate and a ramp for unloading the saw off the container. Raise the saw to its full height. Place the unloading ramp at the edge of the container and roll the saw off the container.

TRANSPORTING

The Soff-Cut **Model X-450** saw weighs approximately 139 pounds (63 kilograms) when ready to use. Use safe lifting practices when handling the saw. Always remove the diamond blade when transporting the saw. Always transport the saw with a skid plate installed. Raise the guide arm to the back position. Loosen the handle locking knob and fold the handle forward. Tighten the handle locking knob making sure the handle is locked in the keyways. The saw can be lifted from the center of the handle. If 2 people are lifting the saw, use the handle bar and lift with 2 hands on each side of the saw. Always store the saw in a completely lowered position and secured from moving.

BLADE AND SKID PLATE INSTALLATION

The Excel Series of diamond blades have been designed specifically for the SoffCut Ultra Early Entry dry cutting system of green concrete. These specialty blades are designed to increase speed and life while cutting a wide range of aggregates. Choose the correct specification of diamond blade for your area as follows:

Purple Excel Series 1000	XL8-1000	Ultra hard aggregate and non abrasive sand
Green Excel Series 2000	XL8-2000	Hard to ultra hard aggregate and non abrasive sand
Red Excel Series 3000	XL8-3000	Hard aggregate, medium abrasive sand
Orange Excel Series 4000	XL8-4000	Medium hard aggregate, medium abrasive sand
Yellow Excel Series 5000	XL8-5000	Medium hard to soft aggregate, abrasive sand
Black Excel Series 6000	XL8-6000	Soft aggregate, highly abrasive sand

With the saw turned off, fold the saw handle to its full upright position and tighten the locking knob. With both hands, push down on the handlebar and raise the saw to its full height and locked position. Remove the blade block cover (A) by turning the 2 locking knobs counter clockwise. Insert the blade wrench supplied with saw on the bolt (C) on the end of the blade shaft in the blade block (J). Rotate the blade shaft counterclockwise with the wrench on the blade shaft bolt while pushing in on the blade shaft locking pin (K) located on the front of the saw frame. The locking pin will drop in the blade shaft and prevent the shaft from rotating. Remove the blade shaft bolt by continuing to turn the bolt counterclockwise. Remove the outer arbor washer or flange (D). **WARNING: Inspect the blade (F) for any damage. Do not use any blade that has cracks, nicks, flaws or a damaged arbor. Make sure the blade is marked with a maximum operating speed greater than 3200 rpm.** Match the blade tri-arbor to the blade shaft arbor and install the blade firmly against the rear flange (H). Insure the blade is installed on the tri-arbor correctly. Match the female tri-arbor of the outer washer or flange with the blade shaft and install the blade shaft bolt turning clockwise while holding the locking pin in. Be sure the outer flange is fully seated and firmly holding the diamond blade in position. Install a new skid plate (G) by hooking the front on the front blade block shaft pin. Connect the rear blade block shaft and the rear of the skid plate by installing the locking pin (B). Install the blade cover by turning the two knobs and tighten until fully seated against the blade block. Lift the front and rear of the skid plate to insure the blade slides through the skid plate freely. Insure the lexan shields (E & I) move freely up and down. When replacing a worn blade, thoroughly clean the concrete from the blade block and blade cover before installing the new blade. Discard the old skid plate and replace it with a new skid plate.

Note: The patented trussed skid plate is the most important part of the Soff-Cut Ultra Early Entry system. If it is bent, twisted or damaged, spalling and raveling of a cut may result. Store skid plates carefully and install them properly. Install a new skid plate with each new blade. Never reuse skid plates.

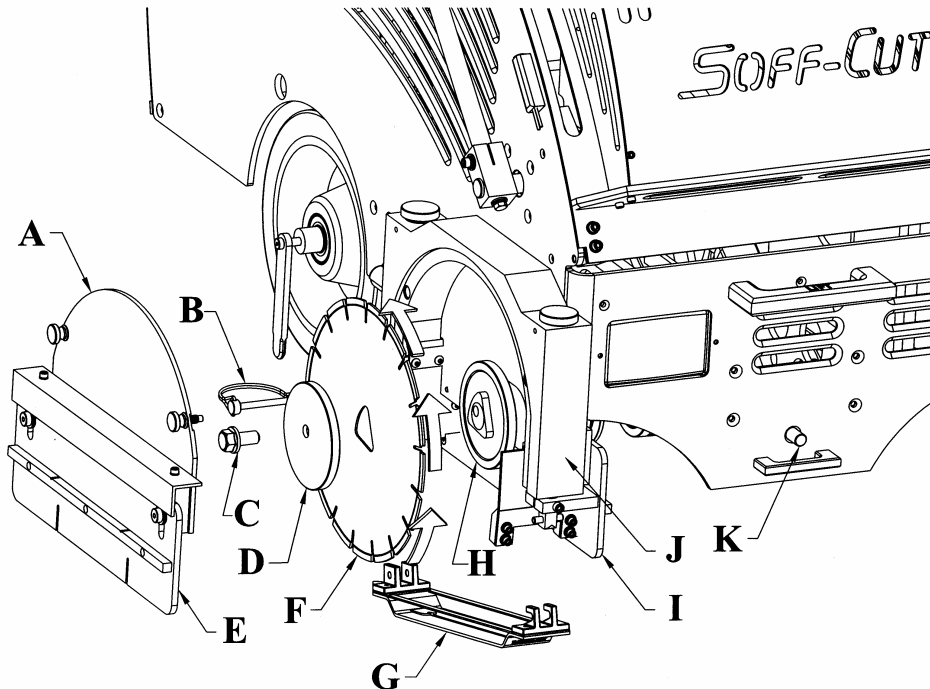

OPERATING INSTRUCTIONS

Experience is very important when running the **X-450** saw. A skilled worker is highly recommended. Always do an inspection of the saw before starting the engine. Open the hood (E) and check the fuel and oil levels per the enclosed engine manual. SAE 10W/30 oil and unleaded gasoline with an 87 or higher octane should be used. **Observe all safety regulations for the safe handling of fuel. Always check the engine oil with the saw turned off, completely lowered and the engine level! Do not screw the oil dipstick into the oil filler neck to check the oil level.** Check that all controls are in good working order. Check for loose bolts or nuts. Check for fuel or oil leaks. **WARNING: Do not operate saw if there is a fuel leak!** Insure all guards are secure, undamaged and properly installed. **WARNING: Do not operate the saw unless all guards, safety equipment and kill switches are in place and operational!** Check the air filter and clean or replace if necessary. Check for proper specification of blade and that the skid plate operates properly. Check that the blade and skid plate are in good condition. Check that the handle (A) is in the full upright and locked position and the handle locking knob (F) is tight. Make sure the work site is clean, well lit and hazard free.

To start the engine, turn the fuel valve on by the carburetor on the side of the engine. Raise the blade by pushing down on the handlebar (A) with both hands to the full and locked position. Push the engine kill switch (N) located on the instrument panel to the "on" or "1" position. Move the engine throttle lever (C) 1/3 of the way to the open position. Close the engine choke (M) by pulling up on the knob. The closed choke position enriches the fuel mixture for starting a cold engine. The open choke position provides the correct fuel mixture for operation after the engine starts and for restarting a warm engine. Start the engine by pulling the rope handle (K) on the back of the saw. After the engine starts, slowly close the choke lever. Allow the engine to warm for a few minutes.

Open the engine throttle lever to the full open position for maximum engine speed shown on the tachometer (L). Lower the front guide (G) by pushing the front guide control lever (B) forward. Line up the saw with the cut line using the white wheel on the front guide, the rear guide (H) on the rear wheel and the triangle pointer on the back of the blade block (J). Push down on the saw handle and pull the blade release lever (D) to lower the blade in the concrete slowly. Push the saw forward to cut keeping the front guide wheel on the cut line. Push the saw at about half speed for the first 50 feet to allow the blade to develop good diamond exposure or open up and promote full blade life. Increase the forward speed of the saw until the blade and engine are working at maximum efficiency. **Do not force the saw.** When approaching a wall, raise the front guide and use the triangle guide at the back of the blade block and the rear guide on the wheel to cut the last few feet. **Do not hit the blade block assembly against any object.** Damage may result. Push down on the back of the handlebar to raise the saw out of the cut to the full and locked position. Move the engine throttle lever to the full closed position. Turn the engine kill switch to the "off" or "0" position. Lower the saw to the down position. **WARNING: Do not leave the saw unattended while the engine is running! Always secure the saw from movement while unattended.** Periodically, clean any excess concrete from inside the blade block, scrapers and blade cover. Always clean the blade block assembly thoroughly before storing the saw. Always close the fuel valve before transporting.

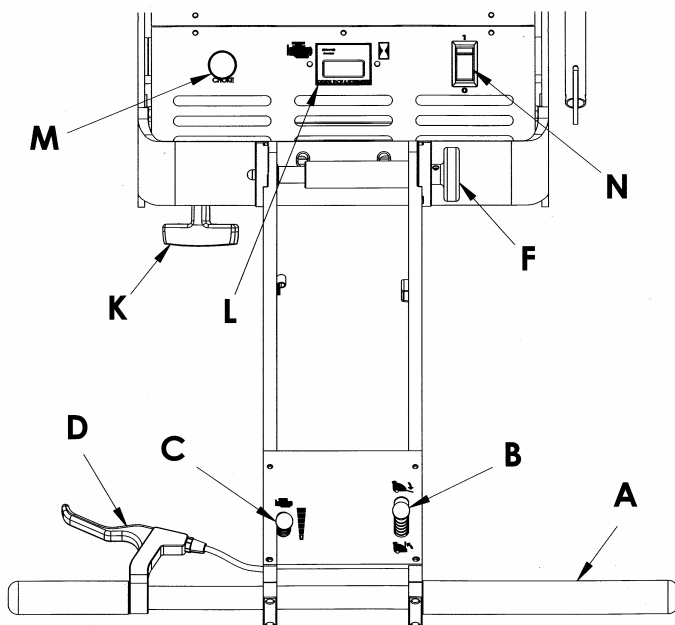

- A – Handlebar
- B – Front guide control
- C – Engine throttle control
- D – Blade release lever
- F – Handle locking knob
- K – Engine starter rope
- L – Tachometer/hour meter
- M – Engine choke
- N – Engine on/off switch

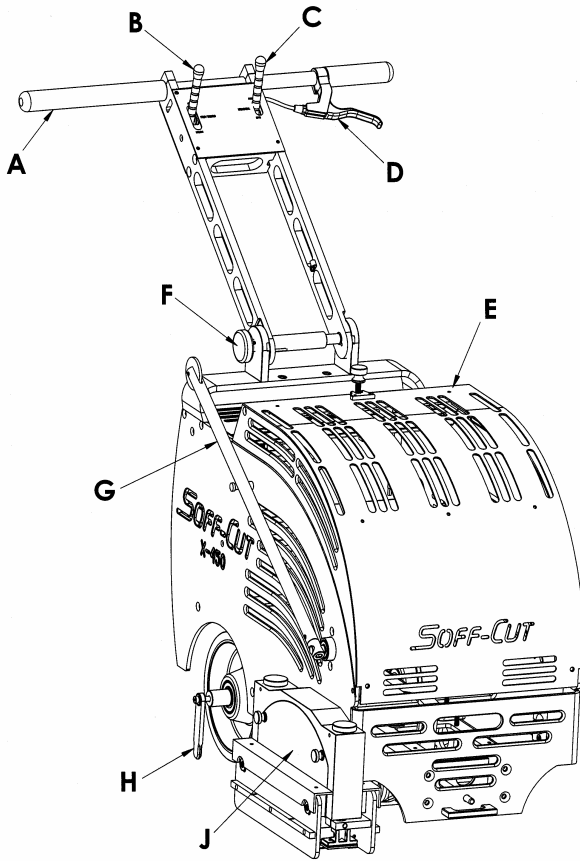

- | | |
|----------|---------------------------|
| A | – Handlebar |
| B | – Front guide control |
| C | – Engine throttle control |
| D | – Blade release lever |
| E | – Hood |
| F | – Handle locking knob |
| G | – Front guide |
| H | – Rear guide |
| J | – Blade block |
| K | – Engine starter rope |

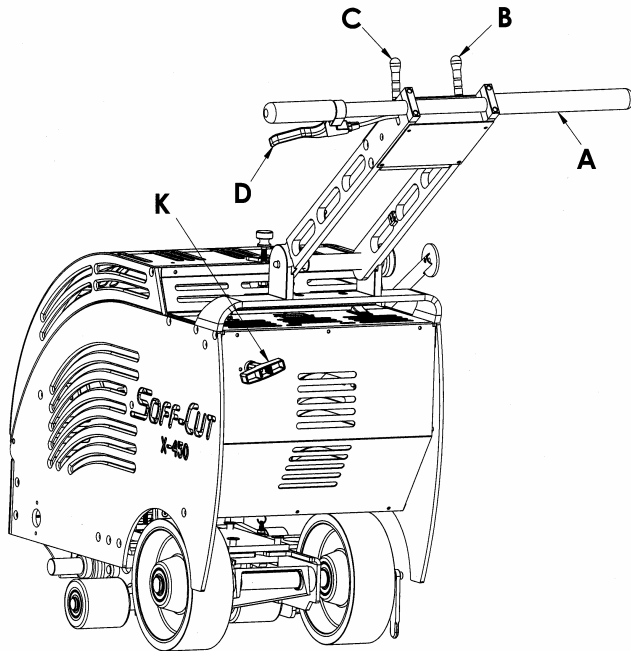

MAINTENANCE

The following maintenance should be performed by the saw owner or operator.

- **Guards** – Check all guards for damage and proper function daily especially the blade block. Blade block and cover should be secure to the saw and not damaged. Lexan side covers on the blade block should move freely up and down.
- **Diamond blade** – Inspect diamond blades daily for damage, cracks, secure fit to the arbor, loss of segments, warping or overheating. **If any blade shows any of these problems, discard the blade and never use.**
- **Skid plate** – Inspect the skid plate daily for damage, excessive wear in the blade slot, burrs on the concrete surface side, twisting and free movement up and down when installed on the blade block. Replace the skid plate with each new diamond blade. Never reuse skid plates or spalling and raveling may result.
- **Saw controls** – Inspect all controls for proper function daily. **Check the engine on/off switch for proper operation.**
- **Cleaning** – Clean the blade block of any excess concrete build up after each use. Keep the handle bars and controls clean and dry. Immediately clean any spilled fuel (D) from the saw. Keep all openings and slots on the saw clean and open so air flows freely through the engine compartment to insure proper cooling.
- **Engine oil** – Check the engine oil level (B) daily with saw fully lowered and the engine level. See the enclosed engine manual for more details. Use SAE 10W-30 viscosity detergent automotive type with API service class SE or higher grade oil. Replace the engine oil and oil filter every 50 hours. The oil drain hose (E) is located on the rear of the saw. Place a pan under the drain and remove the brass cap. Drain the oil and replace the cap. Using a long neck funnel, fill the engine with .6 quarts (.6 liters) of oil. When full, the oil level should be at the top of the crosshatch marks on the dipstick or to the top of the threads on the engine fill hole. The engine is equipped with an oil alert system that will stop the engine if the oil level is low.
- **Air filter** – The air cleaner assembly (C) is a cyclone type that can be accessed from the hood of the saw. The air cleaner element should be replaced every 50 hours. Refer to the supplied engine manual and the “Cyclone Dual-Filter-Element Type” for additional information.
- **Belts** – Inspect the blade drive belts and transmission belt for cracks or signs of wear. The belt tension is controlled by the belt tensioner and does not require adjustment. Inspect the belt tensioner for free movement up and down. Insure the belt tensioner bearings roll freely.
- **Blade shaft bearings** – Lubricate the blade shaft bearings (A) with 3 pumps of Lithium12 based grease every 50 hours. Refer to the engine owner’s manual included with the saw for additional maintenance requirements.

MAINTENANCE SCHEDULE

Check guarding, diamond blade, skid plate, lexan covers, controls and oil levels.	Daily
Clean blade block assembly and saw.	Daily
Replace air cleaner.	Every 50 hours
Replace engine oil. Grease blade shaft bearings.	Every 50 hours
Check blade drive belt, the transmission drive belt and belt tensioners.	Every 50 hours

Any other maintenance or repairs should be done by a competent mechanic or by Soff-Cut personnel only.

WARNING: Do not modify the saw! Use only Soff-Cut International replacement parts. Use of unauthorized parts may create a danger or damage the engine.

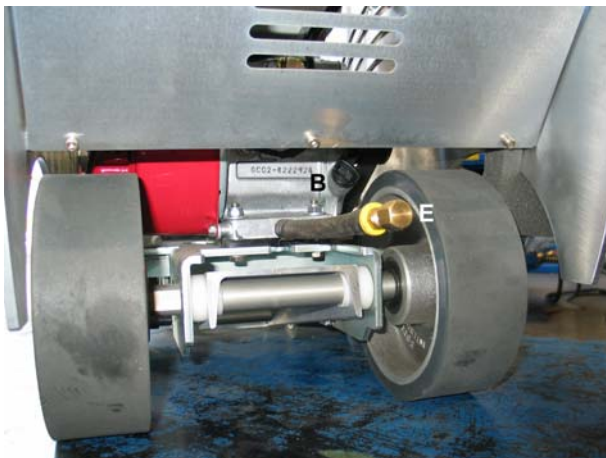

- A – Blade shaft bearing
- B – Oil dipstick & fill
- C – Air filter
- D – Fuel tank
- E – Oil drain hose



SAWING CONTRACTION JOINTS

As concrete hydrates or cures and begins to set, it develops internal stresses which may cause random cracks casting doubt on the quality and workmanship of the concrete. Joints are saw cut in concrete to relieve these stresses before they seek their own relief in the form of a random crack. The Soff-Cut Ultra Early Entry system controls random cracking through the early timing of a saw cut at predetermined locations to create weakened planes in the concrete that subsequently crack at the bottom of the cut to relieve the stress. Soff-Cut sawed contraction joints should be a minimum of 1/8th the concrete depth and a minimum of 1” (25mm) deep. Contraction joints should be sawn as soon as the concrete will support the weight of the saw and the operator without marking or damaging the concrete. There are many possibilities for joint layout. Joint layout should be provided by the project designer, engineer or architect. If the joint layout is not provided, the saw contractor should submit a detailed joint layout for approval prior to cutting. Several factors affect joint spacing including:

- Concrete thickness
- Type, amount and location of reinforcement
- Shrinkage potential of concrete – cement (type, quantity), aggregate (size, quantity, quality), water to cement ratio, admixtures, concrete temperature
- Base friction
- Slab restraints
- Layout of foundations, racks, pits, equipment pads, trenches, etc.
- Environmental factors – temperature, wind, humidity
- Methods and quality of concrete curing.

Generally, contraction joint patterns should divide slabs into approximate square panels per the recommended spacing shown.

RECOMMENDED CONTRACTION JOINT SPACING	
<u>Concrete thickness, in. (mm)</u>	<u>Maximum spacing, ft (m)</u>
3.5 (90)	8 (2.4)
4, 4.5 (100, 114)	10 (3.0)
5, 5.5 (125, 140)	12 (3.6)
6 (150) or greater	15 (4.5)

At all intersecting cross cuts, install Soff-Cut joint protectors at each joint to prevent joint damage. Install an additional joint protector or use the flat steel plates where the right rear wheel will cross the joint to prevent joint damage.

TROUBLESHOOTING

ENGINE WILL NOT START

- Check if there is fuel in the tank and it is the correct fuel. Make sure there is no water in the fuel.
- Check if the fuel valve is turned to the “on” position
- Check if the kill switch is in the “on” position.
- Check that the spark plug wire is connected to the spark plug.
- Engine is flooded. Adjust the choke per the engine owner’s manual.
- Check that the choke is in the “on” position for cold starts. Adjust the choke per the engine owner’s manual.
- Oil level is too low. Engine is equipped with an oil alert system that will not let the engine start unless the engine oil level is within the correct range.
- Check that air filter is not dirty or plugged.
- Check that the blade shaft rotates freely and no concrete has built up in the blade block.

ENGINE RUNS ROUGH, BACK FIRES OR CAN NOT REACH FULL SPEED

- Check if there is fuel in the tank and it is the correct fuel. Make sure there is no water in the fuel.
- Check for correct oil level. Engine oil alert system may function intermittently if oil level is not within the correct range.
- Check that air filter is not dirty or plugged.
- Check that spark plug is clean and properly gapped.
- Check that throttle lever is properly set.

SAW IS SPALLING AND RAVELING CUT

- Check to see if diamond blade is worn out, glazed, warped or damaged.
- Insure skid plate moves freely up and down the entire shaft length without contacting the diamond blade.
- Check skid plate for excessive wear or gap around the diamond blade.
- Check bottom of skid plate for metal burrs or irregularities.
- Check skid plate for tension or loose mounts. Skid plates are preset at the factory.
- Insure skid plate is not twisted or bent.
- Check lexan covers for free movement up and down.
- Insure there is spring down pressure at each end of the skid plate.
- Do not twist or move the saw sideways while cutting.
- Check that the engine is running properly and at full throttle.
- Check belt and belt idler for proper tension.
- Insure the diamond blade is properly mounted and secured with clean flanges.
- Insure that the diamond blade is the correct specification for your area.
- Insure the slab is clean with no debris that could raise the skid plate or saw while cutting.
- Use Soff-Cut joint protectors at all cut intersections.
- Clean excess concrete debris from the blade block assembly
- Check that the scrapers in the blade block are not bent or binding.
- Insure that the blade block shafts are not bent or damaged.

SAW PULLS TO ONE SIDE WHILE SAWING

- Check front guide is properly aligned with the center of the diamond blade.
- Check to see if diamond blade is worn out, glazed, warped or damaged.
- Do not twist or move the saw sideways while cutting. Make gradual changes in pressure on the handlebar to control the saw in the cut.
- Insure that all wheels roll freely and smoothly.
- Do not force the saw. Allow the diamond blade to cut at its own rate of speed.
- Check the skid plate for damage or burrs.

WARRANTY

The SoffCut International gas saw is thoroughly inspected and tested before leaving the factory. It is warranted to be free of defects from workmanship and materials (excluding the engine, which is covered by the engine manufacturer) for a period of six months for labor and up to one year on parts from the date of original purchase.

Before work is performed on any related warranty item, you must submit date of purchase and warranty repair estimate to SoffCut International. This can be done by letter, fax or telephone. SoffCut International will approve the cost or have you ship the unit back to SoffCut International prepaid for repair. Concerning parts that have failed, you can obtain a Returned Goods Authorization (RGA) number from SoffCut International. Send the parts back to SoffCut International prepaid with proof of purchase and the RGA number, and one of the following will happen:

1. Your account will be credited
2. The part will be repaired and returned to you
3. The part will be replaced and sent to you.

Note: SoffCut International is not responsible for shipping costs.

The above SoffCut International warranty does not apply under the following circumstances:

- Repairs made or attempted by others.
- Repairs required because of normal wear and tear.
- The saw has been abused, misused or improperly maintained
- Alterations have been made to the saw.

THE USE OF ANY OTHER BLADE EXCEPT THE ORIGINAL SOFFCUT BLADE PACKAGE MAY VOID THE WARRANTY AND COULD CAUSE INTERNAL DAMAGE TO THE MOTOR.

IN NO EVENT SHALL SOFFCUT INTERNATIONAL BE LIABLE FOR ANY INDIRECT, INCIDENTAL OR CONSEQUENTIAL DAMAGES FROM THE SALE OR USE OF THE PRODUCT. THIS DISCLAIMER APPLIES BOTH DURING AND AFTER THE TERM OF THIS WARRANTY.

SOFFCUT INTERNATIONAL DISCLAIMS LIABILITY FOR ANY WARRANTIES INCLUDING IMPLIED WARRANTIES OF "MERCHANTABILITY" AND "FITNESS FOR A SPECIFIC PURPOSE" AFTER THE TERM OF THIS WARRANTY.

This warranty gives you specific legal rights and other possible rights, which may vary from state to state. Some states do not allow the exclusion or limitation of incidental or consequential damages so the above limitation or exclusion may not apply to you. Some states do not allow limitations on how long an implied warranty lasts so the above limitation may not apply to you.

WARRANTY ON ENGINE

1. SoffCut International does not perform warranty repairs or reimburse for warranty repairs on engines. Engine warranties are provided by the engine manufacturer.
2. To obtain warranty repair: Take your engine along with your proof of purchase to any general purpose dealer or distributor nearest you.

If you are unable to obtain warranty service or are dissatisfied with the warranty service you received, contact the owner of the dealership involved. Normally, this should resolve your problem. For further assistance, call our parts and service department at 1-800-776-3328 or 1-951-272-2330.

Copyright 2006 SoffCut International, Inc.

Covered by one or more of the following U.S. Patents

4769201, 4889675, 4928662, 4938201, 5056499, 5086750, 5184597, 5303688, 5305729, 5373834, 5441033, 5505189, 5507273, 5570677, 5575271, 5579754, 5582899, 5603310, 5660161, 5664553, 5666939, 5689072, 58030371, 6892719.

Other U.S. and foreign patents pending.

Maximizing the Soff-Cut® System

“**The timing of concrete operations – especially finishing and jointing – is critical**”, states a quote from the foreword of the American Concrete Institute (ACI) 302.1R-96. It goes on to say that “Failure to address this issue can contribute to undesirable characteristics in the wearing surface such as cracking...” (it mentions other problems).

The patented Soff-Cut Ultra Early Entry system has revolutionized the method used to control random cracking. While Soff-Cut is being specified more today than ever, sometimes the ultra early-entry spec is not always followed on the job site. When that happens, building owners are not getting what they are paying for or the finished product they expect.

In order for the Soff-Cut system and an experienced Soff-Cut contractor to do a satisfactory job, four components must exist to meet the “specification”:

1. A Soff-Cut Ultra Early Entry dry up-cut saw
2. A Soff-Cut dry-cutting diamond blade
3. A Soff-Cut anti-ravel skid plate installed with every new diamond blade
4. An operator skilled in using the Soff-Cut Ultra Early Entry cutting system.

Without this, joints can not be cut early enough to control random cracking before it starts, which is what the building owner is paying for.

The ACI Spec 302.1R-96 says it best:

“Early-entry dry-cut saws use diamond-impregnated blades and a skid plate that helps prevent spalling. Timely changing of skid plates is necessary to effectively control spalling. It is best to change skid plates in accordance with manufacturer’s recommendations...The goal of saw-cutting is to create a weakened plane as soon as the joint can be cut...The timing of the early-entry process allows joints to be in place prior to development of significant tensile stresses in the concrete...”

The Portland Cement Association (PCA) engineering bulletin, Concrete Floors on Ground, also states:

“Proper jointing can eliminate unsightly random cracks. Aspects of jointing that lead to a good job are choosing the correct type of joint for each location, establishing a good joint pattern and layout, and installing the joint at the correct time...**Timing of joint sawing is critical**...Lightweight, high-speed, early-cut saws have been developed to permit joint sawing very soon after floor finishing, sometimes within 0 to 2 hours...if the cut is sawn within a few hours after final finishing, random cracking can be controlled...”

Soff-Cut has the only Ultra Early Entry dry-cutting system which controls random cracking through the early timing of the cut. With the patented Soff-cut method, control joints are usually cut within 0 to 2 hours after the finishing process. Joint cutting should begin as soon as the concrete will support the weight of the saw and the operator at each joint location and before final set. If the joints are not being cut within this time frame then the Soff-Cut Ultra Early Entry method is not being followed and building owners are not getting what they are paying for or the finished product that they expect.

We hope this information is beneficial to building owners, general contractors, concrete finishers and sawers and the entire industry. For additional information, contact Soff-Cut International, Inc. at (951) 272-2330 or (800) 776-3328, or see our website www.soffcut.com.